



## Product Overview



# NEST IP/MPLS

Network Engineering and Simulation Tool

QoS Design's **NEST IP/MPLS** is the best in class for anyone who has to design an optimized IP network with MPLS support.

*Next Generation IP Network and Traffic Engineering Tool – NEST IP/MPLS is an integrated workbench that proposes unique algorithms for **IP Networks Simulation and Optimization.***

Network operators today are challenged with the need of increased performances and quality triggered by the tremendous development of new IP based applications and services. These improvements shall be planned in quasi real time for more and more complex environments. NEST IP/MPLS addresses the need to streamline this process and to reduce its cost while leveraging key technology differentiators :

///

*Using NEST IP/MPLS, our network planning process has been reduced from weeks to days and we have developed a richness in analysis and reporting which is now one of our most valuable asset ...*

- **NEST IP/MPLS improves productivity** by shortening planning cycle and streamlining mission-critical processes, including planning, engineering, performance analysis, budgeting and reporting.
- **NEST IP/MPLS lowers costs** allowing decision makers "to do more with less" while easing and pacing the planning processes.
- **NEST IP/MPLS provides closed-loop project management**, from strategic planning to performance analysis, through an unified architecture.
- **NEST IP/MPLS delivers value fast** with a low cost of total ownership, providing a network planning solution easy to deploy, learn and use.

///

***NEST Technology, the Foundation of Outstanding Results.***

As all the other NEST modules, IP/MPLS uses an easy to use and deploy unified architecture :

- **NEST is JAVA based** for rapid deployment and anytime/anywhere access and ASP/Portal access.
- **NEST is based on a single centralized database** for total security in multi-users environment and access to virtually any OSS, inventory or IT system.
- **NEST can natively run in parallel on a computer Cluster or GRID** for total scalability.

## NEST IP/MPLS Unique Features.

NEST IP/MPLS has been created to offer to IP network planning teams unbalanced design and traffic engineering capabilities to support MPLS :

- **NEST IP/MPLS supports real networks** as shown below :

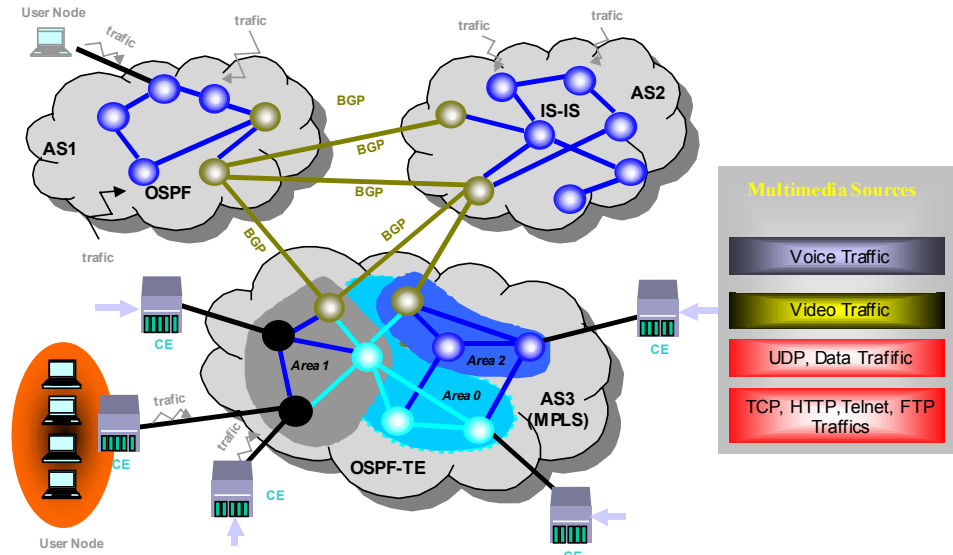

///

*NEST incorporates into a practical operational tool some of the worlds most advanced mathematical theory conceived at LAAS-CNRS. NEST is based on a so strong and advanced technology, that we can now model and simulate awfully complex problems with astonishingly accurate results obtained in hours ...*

///

- **NEST IP/MPLS implements in full the protocols** (OSPF, IS-IS, EIGRP, BGP, MPLS, ...) as well as the traffic sources (voice, video, internet, ...).
- **NEST IP/MPLS models in detail the routers and switches** with extensible models :

### Differentiated Services Switch

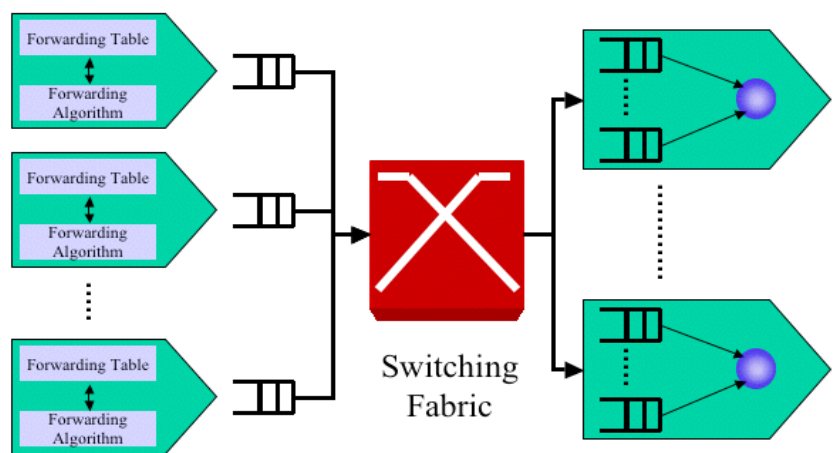

Forwarding

Scheduling  
Buffer Management

- Input and output queues are user definable
- Single or multiple queues buffer are user definable
- All algorithms for DiffServ QoS (shaping, policing, buffer management, scheduling) are adjustable

## NEST IP/MPLS Unique Features.

- **NEST IP/MPLS is an Hybrid Simulation Environment** which allows you to choose network element by network element, or flow by flow element, the type of simulation you need : analytic or event driven. Depending of your choices, you can even end up with a full analytic model or a full event driven model.

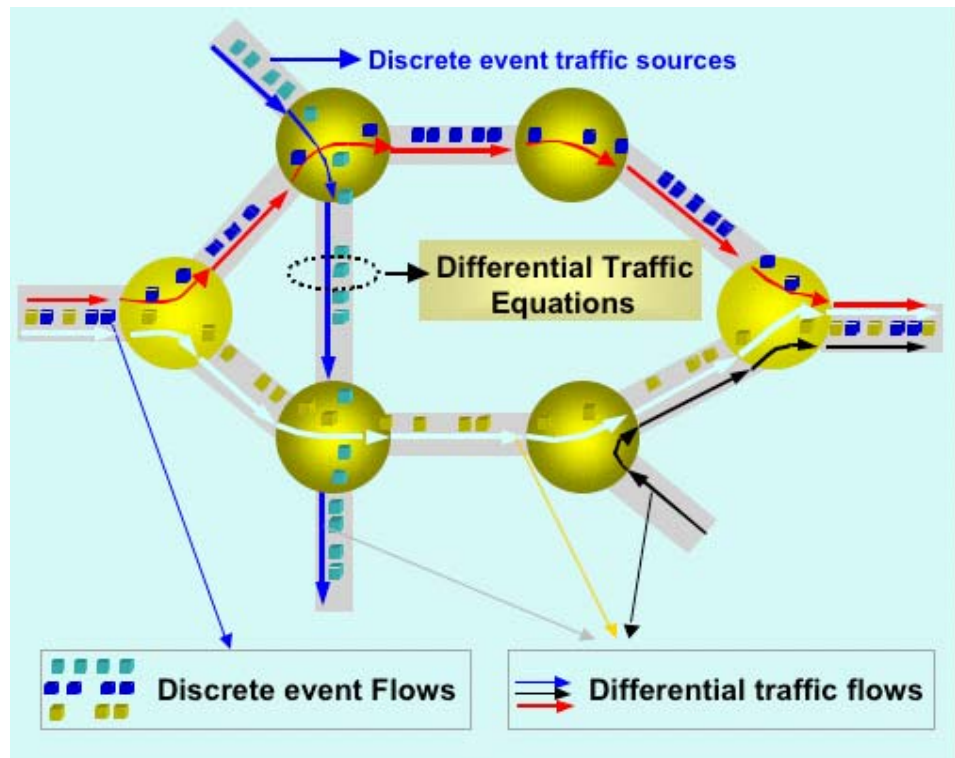

Hybrid Simulation

///

*The hybrid simulation feature of NEST is a powerful theoretical breakthrough. This technology enables studies which were impossible to conduct up to now.*

///

- **NEST IP/MPLS accurately models traffic sources**  
Traffic can be generated in several ways in the simulation:
  - Analytical traffic rates,
  - random generation, on a discrete event basis simulating the real corresponding sources (TCP, audio, video etc.)
  - User defined traffic sources based on generic models
- **The following traffic generators can be used :**
  - Audio (models for Codecs G711, G726 et G729)
  - Video (models for codecs H261)
  - Vidéo (models for codec M-JPEG, MPEG1 [GOP])
  - Data (Telnet, FTP, SMTP, NNTP)
  - Data with a given interarrival distribution (CBR, Gamma, lognormal, Pareto, Poisson ...)
  - TCP (real TCP protocol, Reno, New Reno, Vegas ...)
  - HTTP (HTTP 1.0 et HTTP 1.1)

## ***NEST IP/MPLS General Features.***

- **Traffic Engineering** : NEST IP/MPLS helps you selecting traffic trunks and aggregating them into LSP tunnels.
- **LSPs optimal placement** : NEST IP/MPLS, depending on various parameters such as FECs or LSAs, computes optimized primary paths for the LSPs you have defined. Ingress or Egress nodes can be specified, as well intermediate path segments, priorities, affinities... LSPs are optimized according to nonlinear QoS models for each class of service, bandwidth utilization and various constraints.
- **End to End path protection** : NEST IP/MPLS computes backup paths for all protected primary paths. QoS constraints and bandwidth utilization are also optimized.
- **Traffic grooming** : when the traffic grows or changes, the LSPs can become less efficient. NEST IP/MPLS helps you to analyze this phenomena, to rearrange your in use LSPs and to create new ones where needed.
- **Fast Reroute** : NEST IP/MPLS automates the optimal design of fast rerouting tables and enables the evaluation of links and nodes protection.
- **Failure Analysis** : NEST IP/MPLS allows you to measure the impact of a breakdown at the circuit, link or node level.
- **Capacity Planning** : NEST IP/MPLS helps you to determine which links or nodes can be pruned without jeopardizing the security, the resilience and the performances of the network.
- **Bottleneck Analysis**
- **Multi-Layer modeling** : NEST IP/MPLS allows you to model and tune the interactions of the MPLS layer and the IP Layer.



**QoS DESIGN**

6, Av. Marcel Doret  
31500 Toulouse  
France

[info@qosdesign.com](mailto:info@qosdesign.com)  
[www.qosdesign.com](http://www.qosdesign.com)

## ***NEST IP/MPLS Miscellaneous Features.***

- **Full OSPF, IS-IS and EIGRP Support**
- **Full BGP Support** : NEST IP/MPLS supports inter-AS policy routing and capacity planning.
- **Static Routing Support** : NEST IP/MPLS supports any number of static routing tables.
- **Full Differentiated Services Support** : NEST IP/MPLS supports multiple class mapping, Class Based Weighted Fair Queuing (CB-WFQ) for CoS and many more, such as policy mapping.
- **VPN support** : NEST IP/MPLS supports VPN planning.
- **WEB reports** : all the reports are generated in HTML and can be accessed through web browsers.
- **Open Reports Generation** : since NEST IP/MPLS centralize all its data in a unique relational database, users can define their own reports in native SQL or through tools such as Business Object, Crystal Report or **EXCEL**.
- **Extended Import/Export** : due to the use of a centralized relational database, NEST IP/MPLS eases the importation or exportation of data to/from any other system (OSS, measurement, equipments, ...)